

**Features:**

- Wide band operation over 6.0 to 18.0GHz frequency range
- 1 watt output P-1dB power
- Single positive DC power supply, unconditional stable
- SMA female connector I/O
- Operating temperature -40~+65°C, storage temperature -55~+85°C

**General Description**

ABP2200-27-3330 is a three stage GaAs MMIC HEMT chip based broadband power amplifier module operating in the frequency from 6.0 to 22.0GHz. The amplifier provides 33dB of small signal gain and 30dBm typical output power at 1 dB gain compression point. The amplifier requires only a single positive DC power supply. Its built-in DC voltage regulator allows the amplifier to functional over a range of DC supply voltages without affecting the RF performances.

**Electrical Specifications**

Parameters		Specifications		
		Minimum	Typical	Maximum
Frequency Range	GHz	6.0		22.0
Nominal Gain @25°C base plate temperature	dB	30.0	33.0	36.0
Noise Figure	dB		3.0	5.0
P-1dB Compression Point	dBm	29.0	30.0	
Output IP3	dBm		+40.0	
Gain flatness	dB		+/-1.5	+/-2.0
Gain Variation over Temperature Range	dB		+/-2.0	
Reverse Isolation	dB	50.0		
Input VSWR	-		1.8:1	2.2:1
Output VSWR	-		1.8:1	3.0:1
Spurious	dBc			-60.0
Operating Temperature	°C	-40.0		+75.0
Survival Temperature	°C	-45.0		+125.0
DC Power Supply Voltage	V		+15.0	
DC Power Supply Current	mA	600.0	700.0	850.0
RF In/Out connectors		SMA Female Connectors		
DC Input Connector		Feedthru Pin		
Size	inches	1.90×1.5×0.50		

**Note: External heat sink required for normal operation!!!**

**Functional Diagram**

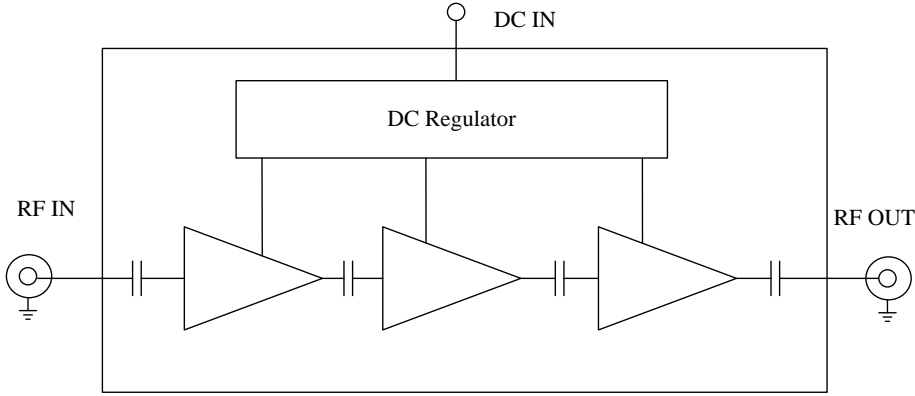

**Mechanical Structure:**

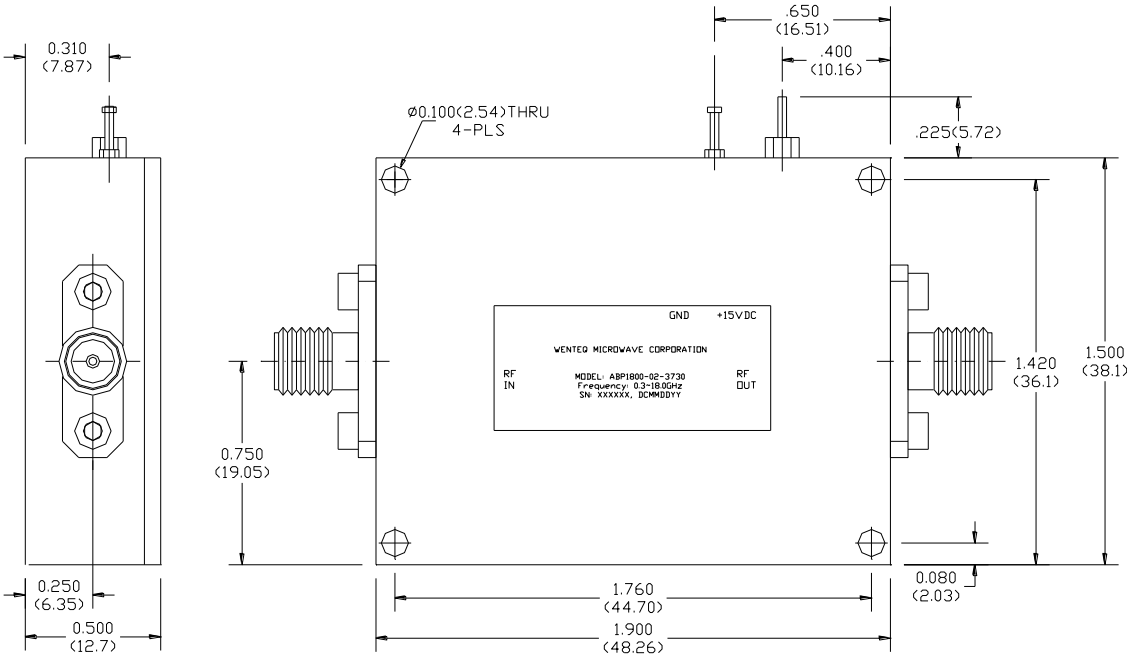

Note: All units in inches (mm).

**Housing Material and Surface Finish:**

- Body and cover material: aluminum
- Surface finish: Gold plated
- Connector material: Stainless steel
- Connector surface finish: passivated

Mechanical Structure with Heatsink

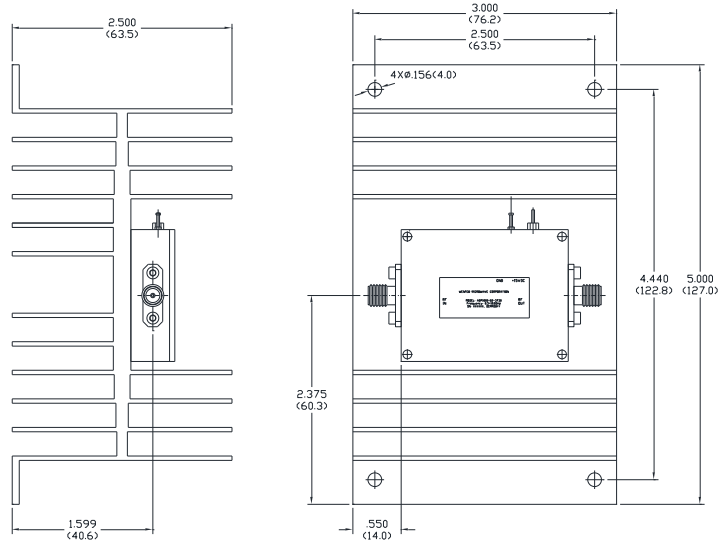

Absolute Maximum Ratings

DC Voltage	+18V
RF Input Power	+15 dBm
Storage Temperature	-55~+125°C
Operating Temperature	-40~+75°C



Electrostatic sensitive device, please observe precautions for handling this amplifier.